

1. NAME OF THE MEDICINAL PRODUCT

NGENLA Solution for Injection in a Pre-filled Pen 24 mg
NGENLA Solution for injection in a Pre-filled Pen 60 mg

2. QUALITATIVE AND QUANTITATIVE COMPOSITION

Each pre-filled pen contains 24 mg or 60 mg of somatrogon. For the full list of excipients, see section 6.1.

3. PHARMACEUTICAL FORM

Solution for injection: 24 mg/1.2 mL (20 mg/mL) or 60 mg/1.2 mL (50 mg/mL) of somatrogon is a clear and colorless to slightly light yellow solution for injection with a pH of 6.6 available as:

- Single-patient-use disposable pre-filled pen containing 24 mg/1.2 mL that delivers a dose in 0.2 mg increments
- Single-patient-use disposable pre-filled pen containing 60 mg/1.2 mL that delivers a dose in 0.5 mg increments

The pre-filled pen is capable of setting and delivering a dose, which is variable, and is determined based on patient body weight.

4. CLINICAL PARTICULARS

4.1. Therapeutic indications

NGENLA is indicated for the treatment of children and adolescents from 3 years of age with growth disturbance due to insufficient secretion of growth hormone (GH).

4.2. Posology and method of administration

Posology

The recommended dose is 0.66 mg/kg body weight administered once weekly by subcutaneous (SC) injection.

For patients switching from daily growth hormone medicinal products, the weekly therapy with NGENLA may be initiated on the day following their last daily injection.

Method of administration

NGENLA can be given in the abdomen, thighs, buttocks, or upper arms. The site of injection should be rotated weekly.

If more than one injection is required to deliver a complete dose, each injection should be administered at a different injection site.

Administer NGENLA once weekly, on the same day each week, at any time of the day.

Dose titration

NGENLA dose may be adjusted as necessary, based on growth velocity, adverse reactions, body weight and serum insulin-like growth factor 1 (IGF-1) concentrations. When monitoring for IGF-1, samples should always be drawn 4 days after the prior dose. IGF-1 values should be maintained below +2 standard deviation score (SDS).

Dose adjustments should be targeted to achieve average IGF-1 SDS levels in the normal range, i.e., between -2 and +2 (preferably close to 0 SDS). In patients whose serum IGF-1 concentrations exceed the mean reference value for their age and sex by more than 2 SDS, the dose of NGENLA should be reduced by 15%. More than one dose reduction may be required in some patients.

Missed dose

If a dose is missed, administer NGENLA as soon as possible within 3 days after the missed dose. If more than 3 days have passed, skip the missed dose and administer the next dose on the regularly scheduled day. In each case, patients can then resume their regular once weekly dosing scheduled.

Changing the dosing day

The day of weekly administration can be changed if necessary as long as the time between two doses is at least 3 days (>72 hours). After selecting a new dosing day, the once weekly dosing should be continued.

Please refer to the Instructions for Use for complete administration instructions.

4.3. Contraindications

Based on experience with daily growth hormone products, NGENLA is contraindicated in patients with active tumors and/or malignancy.

Based on experience with pharmacologic amounts of daily growth hormone products, NGENLA is contraindicated in patients with acute critical illness due to complications following open heart or abdominal surgery, multiple accidental trauma, or acute respiratory failure (see section 4.4).

NGENLA is contraindicated in patients with known hypersensitivity to somatogon (see section 4.4) or any of its excipients (see section 6.1).

4.4. Special warnings and precautions for use

Acute critical illness

There is no clinical experience with NGENLA in patients with acute critical illness.

Treatment with pharmacologic amounts of daily growth hormone products has been associated with increased mortality in patients with acute critical illness due to complications

following open heart surgery, abdominal surgery or multiple accidental trauma, or those with acute respiratory failure (see section 4.3).

Based on experience with daily growth hormone products, if patients who are receiving NGENLA therapy become acutely critically ill, the potential benefit of continued treatment should be weighed against the potential risk (see section 4.3).

Hypersensitivity reactions

Serious systemic hypersensitivity reactions (e.g., anaphylaxis, angioedema) have been reported with daily growth hormone products. If a serious hypersensitivity reaction occurs, immediately discontinue use of NGENLA; treat promptly per standard of care, and monitor until signs and symptoms resolve. Do not use in patients with previous hypersensitivity to NGENLA (see section 4.3).

Hypoadrenalism

Based on published data, patients receiving daily growth hormone therapy who have or are at risk for pituitary hormone deficiency(s) may be at risk for reduced serum cortisol levels and/or unmasking of central (secondary) hypoadrenalism. In addition, patients treated with glucocorticoid replacement for previously diagnosed hypoadrenalism may require an increase in their maintenance or stress doses following initiation of NGENLA treatment (see section 4.5). Monitor patients for reduced serum cortisol levels and/or need for glucocorticoid dose increases in those with known hypoadrenalism (see section 4.5).

Pancreatitis

Although rare, pancreatitis has been reported in somatropin-treated patients. Consider pancreatitis in patients who develop abdominal pain during treatment.

Neoplasm

In childhood cancer survivors, an increased risk of a second neoplasm has been reported in patients treated with somatropin after their first neoplasm. Intracranial tumors, in particular meningiomas, in patients treated with radiation to the head for their first neoplasm, were the most common of these second neoplasms. Monitor patients on NGENLA therapy carefully for increased growth or potential malignant changes of pre-existing nevi. Advise patients/caregivers to report marked changes in behavior, onset of headaches, vision disturbances and/or changes in skin pigmentation or changes in the appearance of pre-existing nevi.

Benign intracranial hypertension

No evidence of benign intracranial hypertension was reported in clinical trials with NGENLA.

Intracranial hypertension (IH) with papilledema, visual changes, headache, nausea, and/or vomiting has been reported in a small number of patients treated with daily growth hormone products. Symptoms usually occurred within the first 8 weeks after the initiation of daily growth hormone therapy. In all reported cases, IH-associated signs and symptoms rapidly

resolved after cessation of therapy or a reduction of the daily growth hormone dose. NGENLA should be temporarily discontinued in patients with clinical or fundoscopic evidence of IH. If treatment with NGENLA is restarted, monitoring for signs and symptoms of IH is recommended.

Glucose metabolism impairment

No clinically meaningful changes in glucose metabolism, including insulin sensitivity, were observed in clinical trials with NGENLA.

Treatment with daily growth hormone products may induce a state of insulin resistance and hyperglycemia. Additional monitoring should be considered in patients treated with NGENLA who have glucose intolerance, or additional risk factors for diabetes. In patients treated with NGENLA who have diabetes mellitus, anti-diabetic therapy may require adjustment (see section 4.5).

Scoliosis

Because NGENLA increases growth rate, signs of development or progression of scoliosis should be monitored during treatment.

Closed epiphyses

In children with closed epiphyses, NGENLA is not recommended to be used for growth promotion.

Thyroid function impairment

In general, peripheral thyroid hormone levels remain within the normal reference range during treatment with somatropin. However, there is an enhanced conversion of T4 to T3 that may result in a reduction in serum T4 and an increase in serum T3 concentrations. This effect may be of clinical relevance for patients with central/subclinical hypothyroidism in whom hypothyroidism may theoretically develop. Based on experience with daily growth hormone products, undiagnosed/untreated hypothyroidism may prevent an optimal response to NGENLA therapy. In patients with growth hormone deficiency (GHD), central (secondary) hypothyroidism may first become evident or worsen during treatment. During NGENLA therapy, thyroid function should be monitored as indicated based on clinical evaluation.

Prader-Willi syndrome

NGENLA has not been studied in patients with Prader-Willi syndrome. NGENLA is not indicated for the long-term treatment of pediatric patients who have growth failure due to genetically confirmed Prader-Willi syndrome unless they also have a diagnosis of GHD. There have been reports of sudden death after initiating therapy with growth hormone in pediatric patients with Prader-Willi syndrome who had one or more of the following risk factors: severe obesity, history of upper airway obstruction or sleep apnea, or unidentified respiratory infection.

Epiphyseal disorders

No epiphyseal disorders were reported with the administration of NGENLA in clinical trials. Epiphyseal disorders, including slipped capital femoral epiphysis may occur more frequently in patients with endocrine disorders or in patients undergoing rapid growth. Any pediatric patient with the onset of a limp or complaints of hip or knee pain during treatment should be carefully evaluated.

Myositis

Myositis is a very rare adverse event that may be related to the preservative metacresol. In the case of myalgia or disproportionate pain at injection site, myositis should be considered and if confirmed, other growth hormone products without metacresol should be used.

4.5. Interaction with other medicinal products and other forms of interaction

Glucocorticoids

In patients receiving concomitant NGENLA and glucocorticoid treatments, glucocorticoid dosing should be carefully monitored to avoid both hypoadrenalism and an inhibitory effect on growth.

The microsomal enzyme 11 β -hydroxysteroid dehydrogenase type 1 (11 β HSD-1) is required for conversion of cortisone to its active metabolite, cortisol, in hepatic and adipose tissue.

Treatment with daily growth hormone products inhibits 11 β HSD-1, reducing serum cortisol concentrations, which may unmask previously undiagnosed central (secondary) hypoadrenalism or render low glucocorticoid replacement doses ineffective (see section 4.4).

Patients treated with cortisone acetate and prednisone may be affected more than others because conversion of these drugs to their biologically active metabolites is dependent on the activity of 11 β HSD-1.

Insulin and/or oral/injectable hypoglycemic agents

In patients with diabetes mellitus requiring drug therapy, the dose of insulin and/or oral/injectable agent may require adjustment when NGENLA therapy is initiated (see section 4.4).

Cytochrome P450 metabolized products

Drug-drug interaction studies have not been performed with somatrogen. Somatrogen has been shown to induce CYP3A4 mRNA expression *in vitro*. The clinical significance of this is unknown. Studies with other human growth hormone (hGH) receptor agonists performed in growth hormone deficient children and adults, and healthy elderly men, suggest that administration may increase the clearance of compounds known to be metabolized by cytochrome P450 isoenzymes, especially CYP3A. The clearance of compounds metabolized by CYP3A4 (e.g., sex steroids, corticosteroids, anticonvulsants and ciclosporin) may be increased and could result in lower exposure of these compounds.

4.6. Fertility, pregnancy and lactation

Fertility

The risk of infertility in males and females of reproductive potential has not been studied in humans. In a rat study, the fertility in males and females was not affected (see section 5.3).

There was an increase in estrous cycle length, copulatory interval, and number of corpora lutea but no effects on mating indices, fertility, or early embryonic development in rats (see section 5.3).

Pregnancy

There are no studies in pregnant women. Animal reproduction studies have not shown evidence of harmful effects on the fetus (see section 5.3). Because animal reproduction studies are not always predictive of human response, NGENLA should be used during pregnancy only if clearly needed.

Somatrogon has been shown not to interfere with blood or urine pregnancy tests.

Lactation

Lactation studies have not been conducted with somatrogon. It is not known whether somatrogon is excreted in human milk. NGENLA should be administered to lactating women only if clearly needed.

4.7. Effects on ability to drive and use machines

No effects on the ability to drive and use machines have been observed.

4.8. Undesirable effects

Summary of the safety profile

The most frequently occurring adverse reactions after treatment with NGENLA are injection site reactions (ISRs) (25.1%), headache (10.7%), and pyrexia (10.2%).

Tabulated list of adverse reactions

Safety data are derived from the phase 2, multi-center safety and dose-finding study, and the pivotal phase 3, multi-center non-inferiority study in pediatric GHD patients (see section 5.1). The data reflect exposure of 265 patients to NGENLA administered once weekly (0.66 mg/kg/week).

Table 1 presents the adverse drug reactions (ADRs) for NGENLA within the system organ class (SOC).

Table 1. ADRs by SOC and Council for International Organizations of Medical Science (CIOMS) frequency category listed in order of decreasing medical seriousness or clinical importance within each frequency category and SOC

System Organ Class	Very Common ≥1/10	Common ≥1/100 to <1/10	Uncommon ≥1/1000 to <1/100	Rare ≥1/10000 to <1/1000	Very Rare <1/10000	Frequency Not Known (Cannot be Estimated From the Available Data)
Blood and lymphatic system disorders	--	Anemia Eosinophilia	--	--	--	--
Endocrine disorders	--	Hypothyroidism	Adrenal insufficiency	--	--	--
Nervous system disorders	Headache	--	--	--	--	--
Eye disorders	--	Conjunctivitis allergic	--	--	--	--
Skin and subcutaneous tissue disorders	--	--	Rash generalized	--	--	--
Musculoskeletal and connective tissue disorders	--	Arthralgia Pain in extremity	--	--	--	--
General disorders and administration site conditions	Injection site reactions Pyrexia	--	--	--	--	--

^a. The term "Injection site reactions" was selected as the cluster term for the following PTs: Injection site bruising, Injection site deformation, Injection site erythema, Injection site hemorrhage, Injection site hypertrophy, Injection site induration, Injection site inflammation, Injection site pain, Injection site pruritus, Injection site swelling, Injection site urticaria, and Injection site warmth.

Long-term exposure

In an open-label extension (OLE) of a safety and dose-finding study (see section 5.1), 37 patients received treatment with somatrogen for at least 5 years. No additional safety findings were reported.

Immunogenicity

In the pivotal safety and efficacy study, among 109 subjects treated with somatrogen, 84 (77.1%) tested positive for anti-drug antibodies (ADAs). There were no clinical or safety effects observed with the formation of antibodies (see section 5.2).

4.9. Overdose

Single doses of NGENLA higher than 0.66 mg/kg/wk have not been studied.

Based on experience with daily growth hormone products, short-term overdosage could lead initially to hypoglycemia and subsequently to hyperglycemia. Long-term overdosage could result in signs and symptoms of gigantism and/or acromegaly consistent with the effects of growth hormone excess.

There is no experience of overdose with NGENLA. Treatment of overdose with NGENLA should consist of general supportive measures.

5. PHARMACOLOGICAL PROPERTIES

5.1. Pharmacodynamic properties

Mechanism of action

Somatrogon is a glycoprotein produced in Chinese Hamster Ovary (CHO) cells by recombinant DNA technology. It is comprised of the amino acid sequence of human growth hormone (hGH) with one copy of the C-terminal peptide (CTP) from the beta chain of human chorionic gonadotropin (hCG) at the N-terminus and two copies of CTP (in tandem) at the C-terminus. The glycosylation and CTP domains account for the half-life of somatrogon, which allows for weekly dosing.

Somatrogon binds to the GH receptor and initiates a signal transduction cascade culminating in changes in growth and metabolism. Consistent with GH signaling, somatrogon binding leads to activation of the STAT5b signaling pathway and increases the serum concentration of IGF-1. IGF-1 was found to increase in a dose-dependent manner during treatment with somatrogon partially mediating the clinical effect. As a result, GH and IGF-1 stimulate metabolic changes, linear growth, and enhance growth velocity in pediatric patients with GHD.

Pharmacodynamic effects

Somatrogon increases IGF-1. Pharmacodynamic evaluations were performed approximately 96 hours after dose administration in order to assess the mean IGF-1 SDS over the dosing interval (see Figure 1).

Figure 1. Modeled IGF-1 SDS profiles in pediatric patients with GHD during 12 months of treatment with somatrogon

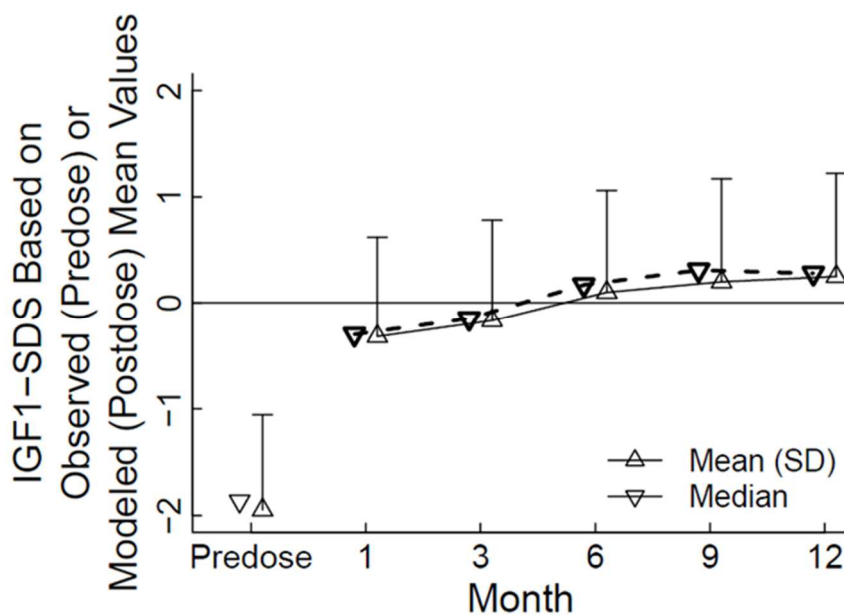

Clinical trials data on efficacy

The safety and efficacy of NGENLA for the treatment of pediatric patients with GHD were evaluated in two multi-center randomized, open-label controlled clinical studies. Both studies included a 12-month main study period that compared once weekly NGENLA to Genotropin administered once daily followed by a single arm open-label extension (OLE) period during which all patients were administered NGENLA once weekly. The primary efficacy endpoint for both studies was annualized height velocity (HV) following 12 months of treatment. Other endpoints reflective of catch-up growth such as change in height SDS from baseline and height SDS were also evaluated in both studies.

In an initial safety and dose-finding study, 53 pediatric patients with GHD were randomized and treated with one of 3 doses of once weekly NGENLA [0.25 mg/kg/wk (N=13), 0.48 mg/kg/wk (N=15), 0.66 mg/kg/wk (N=14)] or Genotropin administered once daily [(0.034 mg/kg/day (N=11)]. The annual HV of 0.66 mg/kg/wk of NGENLA was comparable to Genotropin administered once daily after 12 months of treatment (11.4 cm/yr [95% CI: 9.2, 13.7]); (12.5 cm/yr [95% CI: 11.0, 13.9]), respectively. During the OLE, 37 patients received 0.66 mg/kg/wk of NGENLA for at least 5 years. A progressive gain in height SDS from baseline was observed at 5 years (cumulative change in height SDS mean (SD)=3.11 (1.18), median=2.86).

The 0.66 mg/kg/wk dose of NGENLA was further evaluated in a definitive safety and efficacy study in 224 pre-pubertal pediatric patients with GHD. Patients were randomized and treated with once weekly NGENLA (N=109) or Genotropin administered once daily (N=115) at a dose of 0.034 mg/kg/day. Once weekly NGENLA resulted in a non-inferior HV at 12 months compared to Genotropin administered once daily. Catch-up growth as reflected by change in height SDS from baseline was numerically higher for NGENLA (see Table 2). Once weekly NGENLA also produced an increase in IGF-1 SDS values, from a mean of -1.95 at baseline to a mean of 0.65 at 12 months.

Table 2. Efficacy of NGENLA compared to Genotropin in pediatric patients with GHD at Month 12

Treatment Parameter	Treatment Group		LSM Difference (95% CI)
	NGENLA (N=109)	Genotropin (N=115)	
	LSM Estimate	LSM Estimate	
Height Velocity (cm/yr)	10.10	9.78	0.33 (-0.24, 0.89)
Height Standard Deviation Score	-1.94	-1.99	0.05 (-0.06, 0.16)
Change in Height Standard Deviation Score from baseline	0.92	0.87	0.05 (-0.06, 0.16)

Abbreviations: CI=confidence interval; GHD=growth hormone deficiency; LSM=least square mean; N=number of patients randomized and treated

In the definitive safety and efficacy study, the mean age across the treatment groups, was 7.7 years (min 3.01, max 11.96), 40.2% of patients were >3 years to ≤7 years, 59.8% were >7 years. 71.9% of patients were male and 28.1% were female. In this study 74.6% of patients were White, 20.1% were Asian; 0.9% were Black. Baseline disease characteristics were balanced across both treatment groups. Approximately 68% of patients had peak plasma

growth hormone (GH) levels of ≤ 7 ng/mL, and the mean height was below -2 standard deviation score (SDS).

The most frequently reported all-causality adverse events that occurred in $\geq 5\%$ of subjects in any treatment group were injection site pain, nasopharyngitis, headache, pyrexia, cough, injection site erythema, vomiting, bronchitis, arthralgia, blood creatinine phosphokinase increased, anemia, pharyngitis, hypothyroidism, otitis media, ear pain, oropharyngeal pain, rhinitis, arthropod bite, injection site pruritus, abdominal pain upper, and tonsillitis.

Treatment burden

The impact of NGENLA administered once weekly (0.66 mg/kg/wk) on treatment burden was compared to daily Genotropin in a phase 3 randomized, open-label, crossover study in 87 pediatric patients with GHD. NGENLA administered once weekly demonstrated significantly lower treatment burden, assessed as the difference in mean overall Life Interference total score, compared to Genotropin administered once daily.

Treatment experience with NGENLA resulted in lower treatment burden for the caregiver, greater patient convenience, greater intent to comply, and patient preference for a once weekly administration regimen compared to Genotropin administered once daily.

5.2. Pharmacokinetic properties

Somatrogon pharmacokinetics (PK) was assessed using a population PK approach for NGENLA in 42 pediatric patients (age range 3-15.5 years) with GHD.

Absorption

Following SC injection, serum concentrations increased slowly, peaking 6 to 18 hours after dosing.

In pediatric patients with GHD, somatrogon exposure increases in a dose-proportional manner for doses of 0.25 mg/kg/wk, 0.48 mg/kg/wk and 0.66 mg/kg/wk. There is no accumulation of somatrogon after once weekly administration. In pediatric patients with GHD, the mean population PK estimated steady-state peak concentrations following 0.66 mg/kg/wk was 690 ng/mL.

Distribution

In pediatric patients with GHD, the mean population PK estimated apparent central volume of distribution was 0.812 L/kg and apparent peripheral volume of distribution was 0.169 L/kg.

Metabolism

The metabolic fate of somatrogon is believed to be classical protein catabolism, with subsequent reclamation of the amino acids and return to the systemic circulation.

Elimination

In pediatric patients with GHD, the mean population PK estimated apparent clearance was 0.0336 L/h/kg. With a mean population PK estimated effective half-life of 28.3 hours, somatrogon will be present in the circulation for about 6 days after the last dose.

Excretion

Excretion was not evaluated in clinical studies.

Special populations

Age, race, gender, body weight

Based on population PK analyses, age, sex, race, and ethnicity do not have a clinically meaningful effect on the pharmacokinetics of somatrogon in pediatric patients with GHD. The exposure of somatrogon decreases with an increase in body weight. However the somatrogon dosing regimen of 0.66 mg/kg/wk provide adequate systemic exposure over the body weight range of 10 to 54 kg evaluated in the clinical studies. The effects of individual intrinsic factors on the pharmacokinetics of somatrogon are shown in Figure 2.

Figure 2. Impact of individual intrinsic factor on somatrogon exposure

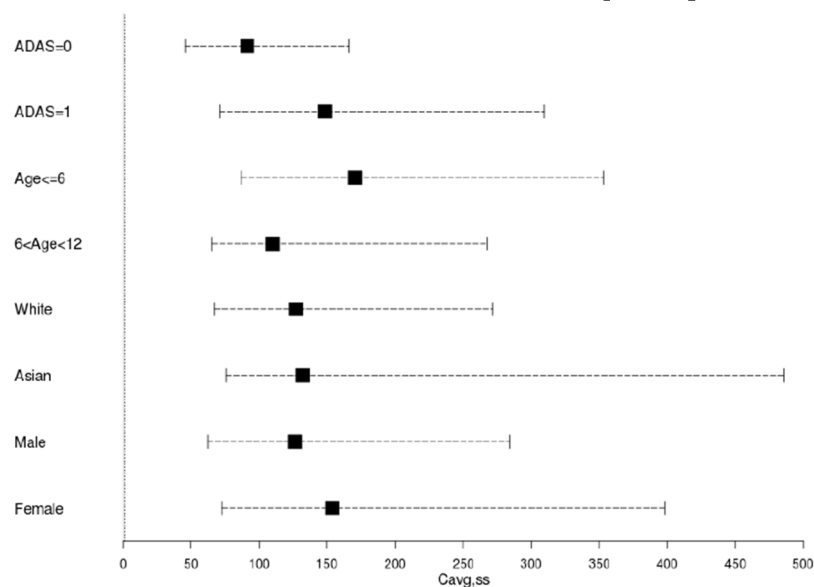

Abbreviations: ADAS=anti-drug antibody status, 0=negative, 1=positive

Patients with renal impairment

NGENLA has not been studied in patients with renal impairment.

Patients with hepatic impairment

NGENLA has not been studied in patients with hepatic impairment.

Immunogenicity

Consistent with the potentially immunogenic properties of protein and peptide pharmaceuticals, patients treated with NGENLA may develop antibodies to somatrogen.

The detection of antibody formation is highly dependent on the sensitivity and specificity of the assay. Additionally, the observed incidence of antibody (including neutralizing antibody) positivity in an assay may be influenced by several factors including assay methodology, sample handling, timing of sample collection, concomitant medications, and underlying disease. For these reasons, comparison of the incidence of antibodies to somatrogen in the studies described below with the incidence of antibodies in other studies or to other products may be misleading.

In the definitive safety and efficacy study, among 109 subjects treated with somatrogen, 84 (77.1%) tested positive for ADAs. There were no serious adverse drug reactions, or serious immune-related toxicities reported in patients with or without ADAs. In addition, annual height velocity, change in height SDS, height SDS, and IGF-1 response were similar in patients with or without treatment-emergent ADAs (see section 5.1).

5.3. Preclinical safety data

Somatrogen has been evaluated in single- and repeat-dose toxicity studies in rats and rhesus monkeys. Based on the nonclinical studies conducted, injection site findings have been identified as the only target organ/effect. An anticipated increase in body weight was observed in rats since it is a primary pharmacodynamic effect of growth hormone and associated with secondary effects of increased IGF-1. Other findings related to the pharmacological activity of somatrogen occurred in mammary glands, liver, kidney, and spleen in rats.

Impairment of fertility

The potential for somatrogen to have effects on fertility and early embryonic development was evaluated in male and female rats. In an embryo-fetal development study in rats administered somatrogen via SC injection every 2 days from Gestation Day (GD) 6 to 18 at doses up to 30 mg/kg [45 times the maximum recommended human dose based on average concentration (C_{ave}) exposure], there were no adverse maternal or embryo-fetal effects. Somatrogen elicited an increase in estrous cycle length, copulatory interval, and number of corpora lutea, but there was no impact on mating indices, fertility, number of viable embryos/early embryonic development (see section 4.6).

Developmental toxicity

The potential for somatrogen to have effects on embryo-fetal development was also assessed in rats. Somatrogen elicited pharmacologically-mediated, nonadverse, increases in maternal body weights and body weight gain, but there were no corresponding embryo-fetal effects.

The potential for effects of somatrogen on prenatal and postnatal development was evaluated in rats. In a pre- and postnatal development study in rats, somatrogen was administered via SC injection to pregnant rats every 2 days from GD 6 to Lactation Day 20 at doses up to 30 mg/kg. There was no evidence of maternal toxicity and no adverse effects on the first

generation (F1) offspring. Somatrogen elicited an increase in F1 mean body weights (both sexes) as well as an increase in the mean copulatory interval in F1 females at the highest dose (30 mg/kg), which was consistent with a longer estrous cycle length; however, there were no associated effects on mating indices.

Genotoxicity and carcinogenicity

Genotoxicity and carcinogenicity studies have not been performed. The potential for mitogenic activity of somatrogen was assessed in the 26-week repeat-dose toxicity study in rhesus monkeys. No mitogenicity was evident from macroscopic and microscopic tissue evaluations or from evaluation of organ weights in this study.

6. PHARMACEUTICAL PARTICULARS

6.1. List of excipients

Citric acid monohydrate
L-Histidine
m-Cresol
Trisodium citrate dihydrate
Poloxamer 188
Sodium chloride
Water for injection
Sodium hydroxide

6.2. Incompatibilities

In the absence of compatibility studies, this medicinal product must not be mixed with other medicinal products.

6.3. Shelf life

Before first use

NGENLA is stored at 2°C to 8°C.
Refer to outer carton for expiration date.

Before first use, store NGENLA in a refrigerator. The unopened pre-filled pen may temporarily be held for up to 4 hours at temperatures up to 32°C.

After first use

28 days.
Store in a refrigerator (2°C to 8°C).

6.4. Special precautions for storage

After first use of NGENLA, the pre-filled pen can be stored for up to 28 days of use in a refrigerator 2°C to 8°C. Store away from direct sunlight. Always remove and safely discard the needle after each injection and store the NGENLA pre-filled pen without an injection

needle attached. Always use a new needle for each injection. Replace the cap on your pre-filled pen when it is not in use. The pre-filled pen should not be used more than 28 days after first use and should not be used beyond the expiration date.

Store the pre-filled pen at 2°C to 8°C in between each use. NGENLA may be held at room temperature (up to 32°C) for up to 4 hours with each injection for a maximum of 5 times. Return NGENLA to the refrigerator again after each use. Do not expose NGENLA to temperatures above 32°C or leave at room temperature for more than 4 hours with each use.

The NGENLA pen should be discarded if it has been used 5 times, if it has been exposed to temperatures higher than 32°C, or if it has been removed from the refrigerator for more than 4 hours with each use.

Chemical and physical in-use stability has been demonstrated for 28 days from the date of first use of the pre-filled pen, when the pre-filled pen has been stored at 2°C to 8°C in between each use.

6.5. Nature and contents of container

Each carton contains one single-patient-use, disposable pre-filled pen containing a preserved solution of somatrogon in a Type 1 glass cartridge. Each pre-filled pen is able to provide variable doses based on patient body weight. The medicinal product, the primary container (cartridge, bilayer disc seal, plunger stopper) and the pre-filled pen are not made with natural rubber latex.

NGENLA pre-filled pen is available in the following packages:

	24 mg Pre-filled Pen	60 mg Pre-filled Pen
Somatrogon solution concentration	20 mg/mL	50 mg/mL
Volume	1.2 mL	1.2 mL
Color	Lilac pen cap, injection button, and label	Blue pen cap, injection button, and label
Dose increments	0.2 mg/0.01 mL	0.5 mg/0.01 mL
Maximum single-dose	12 mg (0.6 mL)	30 mg (0.6 mL)

Sterile needles are required for administration but not included. Consult the Instructions for Use for needles that can be used.

Not all presentations may be available locally.

6.6 Special precautions for disposal and other handling

Each NGENLA pre-filled pen is for use by a single patient. A NGENLA pre-filled pen must never be shared between patients, even if the needle is changed.

Do not inject the medicine if it is cloudy or dark yellow. Do not shake, shaking can damage the medicine.

Dose preparation

The pen may be used straight from the refrigerator. For a more comfortable injection, allow the pre-filled pen containing the sterile solution of somatogon to reach room temperature up to 32°C for up to 30 minutes. Inspect the solution in the pen for flakes, particles, and coloration. Do not shake. If flakes, particulates, or discoloration are observed, do not use the pen.

Administration

Prepare the designated injection site as instructed in the instructions for use. It is recommended to rotate the injection site at each administration. Rotate the site of injection weekly. Always use a new sterile needle for each injection.

Disposal

Any unused product or waste material should be disposed of in accordance with local requirements. If the pre-filled pen is empty, has been exposed to temperatures higher than 32°C, has been removed from the refrigerator for more than 4 hours with each use, has been used 5 times, or it has been more than 28 days after first use, it should be disposed of even if it contains unused medicinal product.

7. PRODUCT OWNER

Pfizer Inc.
New York
United States

Instructions for use *NGENLA 24 mg Pen*

Injection for subcutaneous (under the skin) use only
Keep this leaflet. These instructions show step-by-step directions on how to prepare and give a NGENLA injection.

Important information about your NGENLA pen

- NGENLA for injection is a multi-dose pre-filled pen containing 24 mg of medicine.
- NGENLA for injection can be given by a patient, caregiver, doctor, nurse or pharmacist. **Do not** try to inject NGENLA yourself until you are shown the right way to give the injections and read and understand the Instructions for use. If your doctor, nurse or pharmacist decides that you or a caregiver may be able to give your injections of NGENLA at home, you should receive training on the right way to prepare and inject NGENLA. It is important that you read, understand, and follow these instructions so that you inject NGENLA the right way. It is important to talk to your doctor, nurse or pharmacist to be sure you understand your NGENLA dosing instructions.
- To help you remember when to inject NGENLA, you can mark your calendar ahead of time. Call your doctor, nurse or pharmacist if you or your caregiver have any questions about the right way to inject NGENLA.
- Each turn (click) of the dose knob increases the dose by 0.2 mg of medicine. You can give from 0.2 mg to 12 mg in a single injection. If your dose is more than 12 mg, you will need to give more than 1 injection.
- A small amount of the medicine may remain in the pen after all doses have been correctly given. This is normal. Patients should not try to use the remaining solution but get rid of the pen in the correct way.
- **Do not** share your pen with other people, even if the needle has been changed. You may give other people a serious infection, or get a serious infection from them.
- Always use a new sterile needle for each injection. This will reduce the risk of contamination, infection, leakage of medicine, and blocked needles leading to the wrong dose.
- **Do not** shake your pen. Shaking can damage the medicine.
- The pen is **not recommended** for use by the blind or visually impaired without the assistance of a person trained in the proper use of the product.

Supplies you will need each time you inject

Included in the carton:

- 1 NGENLA 24 mg pen.

Not included in the carton:

- 1 new sterile needle for each injection.
- Alcohol swabs.
- Cotton balls or gauze pads.
- Adhesive bandage.
- A suitable sharps disposal container for disposal of pen needles and pens.

NGENLA 24 mg pen:

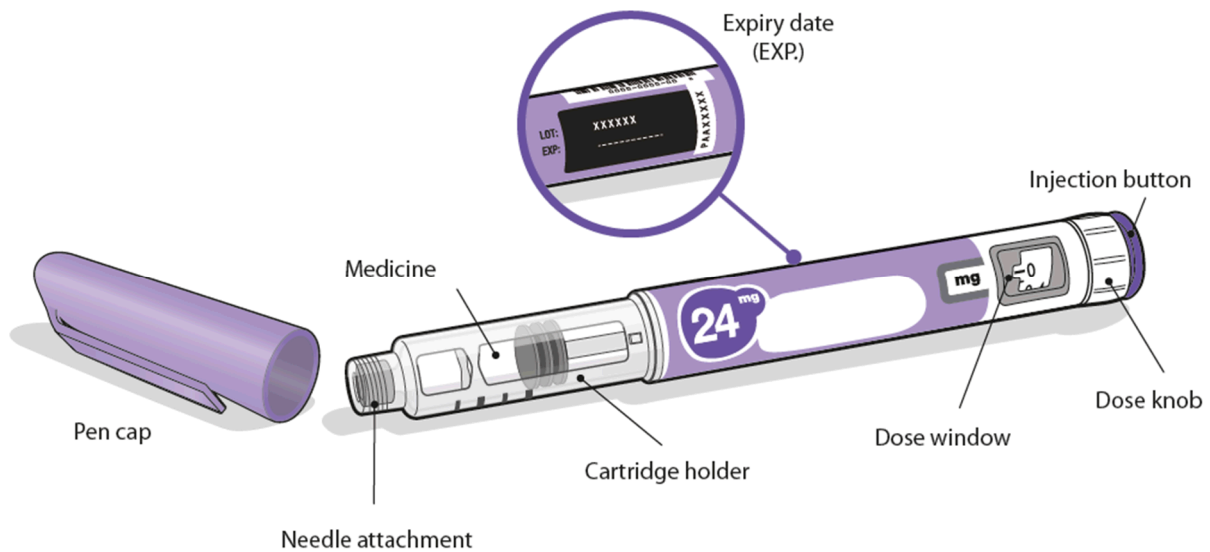

Needles to use

Pen needles are **not included** with your NGENLA pen. You can use pen needles up to a length of 8 mm.

- Needles to use with your NGENLA pen:
 - 31G or 32G
- Talk with your doctor, nurse or pharmacist about the right needle for you.

Sterile needle (example) not supplied:

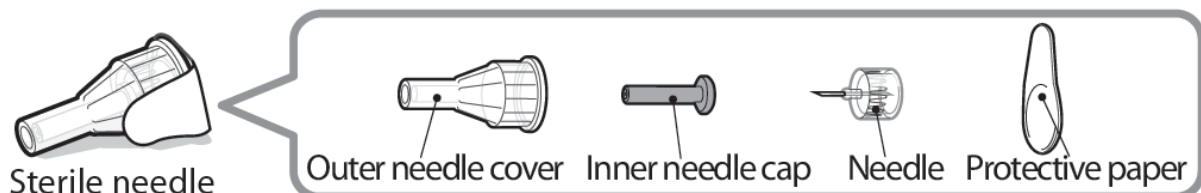

Caution: Never use a bent or damaged needle. Always handle pen needles with care to make sure you do not prick yourself (or anyone else) with the needle. **Do not** attach a new needle to your pen until you are ready for your injection.

Preparing for your injection

Step 1 Getting ready

- Wash and dry your hands.
- You can use your pen straight from the refrigerator. For a more comfortable injection, leave your pen at room temperature for up to 30 minutes. (See sections 6.3, 6.4 and 6.6).
- Check the name, strength, and label of your pen to make sure it is the medicine your doctor has prescribed for you.
- Check the expiry date on the pen label. **Do not** use if the expiry date has passed.
- **Do not** use your pen if:
 - it has been frozen, exposed to heat (above 32°C) or it has been more than 28 days after first use of the pen. (See sections 6.3 and 6.4).
 - it has been dropped
 - it looks broken or damaged
- **Do not** remove the pen cap from your pen - until you are ready to inject.

Step 2 Choose and clean your injection site

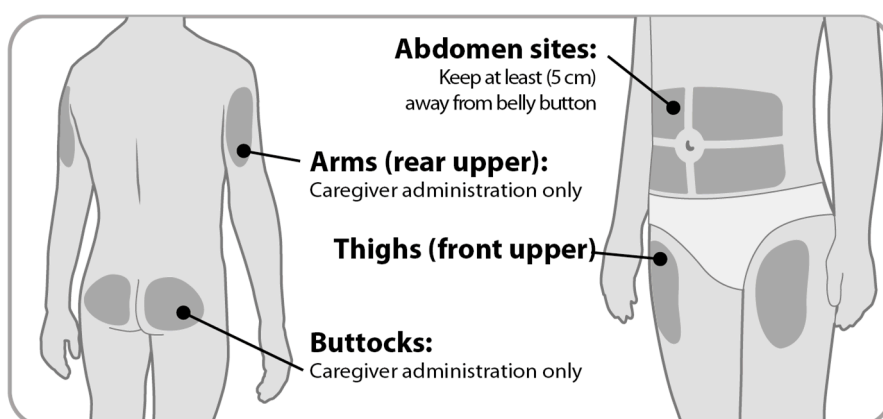

- NGENLA can be given in the abdomen (belly), thighs, buttocks, or upper arms.
- Choose the best place to inject, as recommended by your doctor, nurse or pharmacist.
- If more than 1 injection is needed to complete your full dose, each injection should be given in a different injection site.
- **Do not** inject into bony areas, areas that are bruised, red, sore or hard, and areas that have scars or skin conditions.
- Clean the injection site with an alcohol swab.
- Allow the injection site to dry.
- **Do not** touch injection site after cleaning.

Step 3 Check medicine

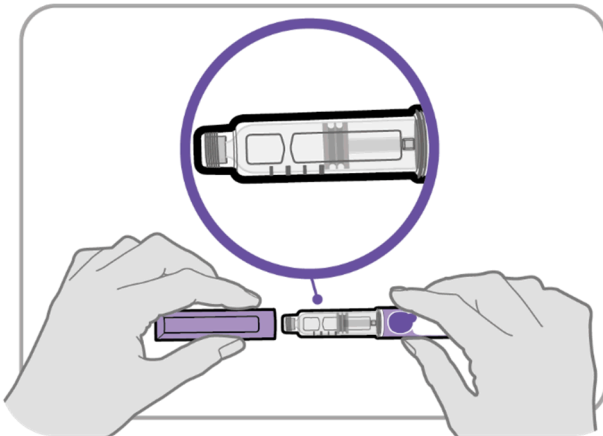

- Pull off the pen cap and keep it for after your injection.
- Check the medicine inside the cartridge holder.
- Make sure the medicine is clear and colorless to slightly light yellow. **Do not** inject the medicine if it is cloudy or dark yellow.
- Make sure the medicine is free of flakes or particles. **Do not** inject the medicine if it has flakes or particles.

Note: It is normal to see one or more bubbles in the medicine.

Step 4 Attach needle

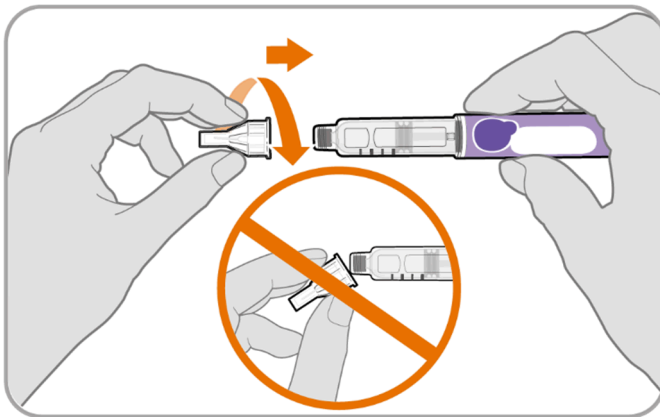

- Take a new needle and pull off the protective paper.
- Line the needle up with your pen keeping them both straight.
- Gently push and then screw the needle onto your pen.
Do not over tighten.

Note: Be careful not to attach the needle at an angle. This may cause the pen to leak.

Caution: Needles have sharp tips at both ends. Handle with care to make sure you do not prick yourself (or anyone else) with the needle.

Step 5 Pull off outer needle cover

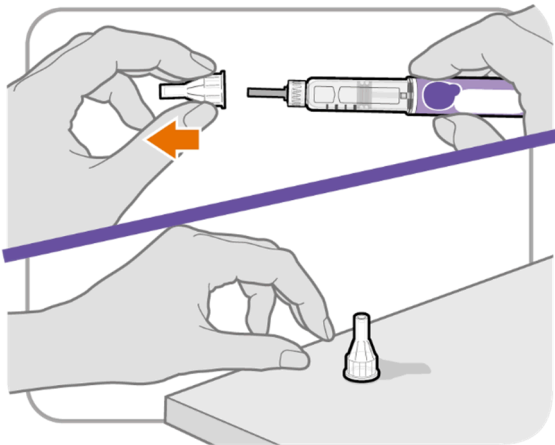

- Pull off the outer needle cover.
- Make sure you keep the outer needle cover. You will need it later to remove the needle.

Note: You should see an inner needle cap after you have removed the outer cover. If you do not see this, try to attach the needle again.

Step 6 Pull off inner needle cap

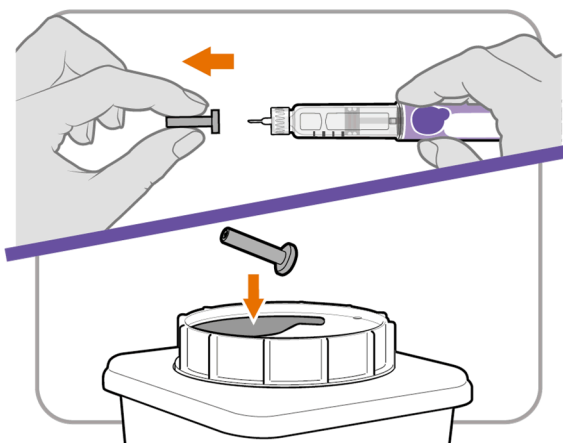

- Pull off the inner needle cap carefully to show the needle.
- Throw away the inner needle cap in a sharps container. It is not needed again.

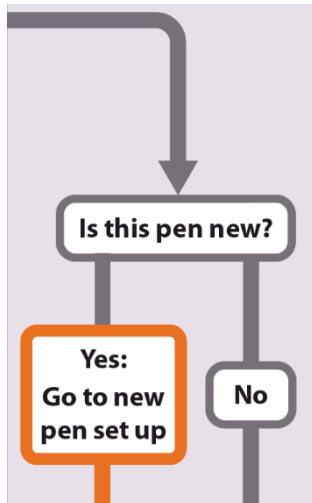

(‘Yes: Go to new pen set up’ has an arrow directing to ‘New pen set up (priming)’ and ‘No’ has an arrow directing to ‘Setting your prescribed dose’)

New pen set up (priming) – for the first use of a new pen only

You must set up each new pen (priming) before using it for the first time

- New pen set up is done before each new pen is used for the first time.
- The purpose of setting up a new pen is to remove air bubbles and make sure you get the correct dose.

Important: Skip Step-A through to Step-C if you have already set up your pen.

Step-A: Set knob to 0.4

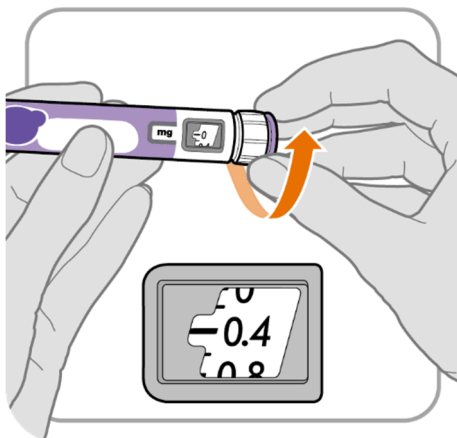

- Turn the dose knob to **0.4**.
Note: If you turn the dose knob too far, you can turn it back.

Step-B: Tap cartridge holder

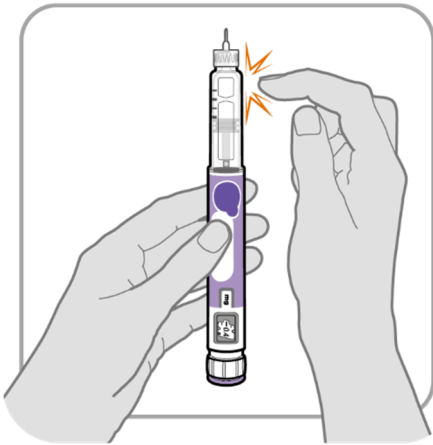

- Hold the pen with the needle pointing up so that the air bubbles can rise.
 - **Tap** the cartridge holder gently to float any air bubbles to the top.
- Important:** Follow Step-B even if you do not see air bubbles.

Step-C: Press button and check for liquid

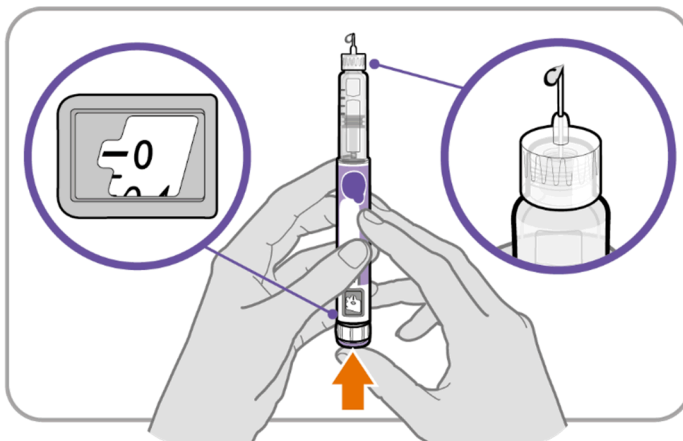

- **Press the injection button** until it cannot go any further and “0” is shown in the dose window.
 - **Check** for liquid at the needle tip. If liquid appears, your pen is set up.
 - Always make sure that a drop of liquid appears before you inject. If liquid has not appeared, repeat Step-A through to Step-C.
 - If liquid does not appear after you have repeated Step-A through Step-C five (5) times, attach a new needle and try one (1) more time.
- Do not** use the pen if a drop of liquid still does not appear. Contact your doctor, nurse or pharmacist, and use a new pen.

Setting your prescribed dose

Step 7 Set your dose

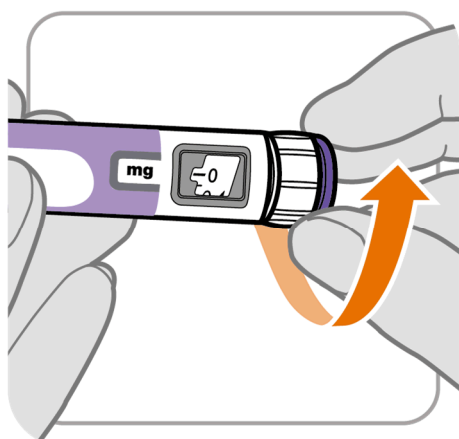

Example A:

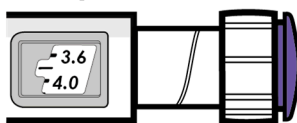

3.8 mg shown in the dose window

Example B:

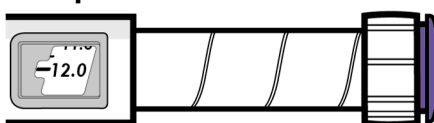

12.0 mg shown in the dose window

- Turn the dose knob to set your dose.
 - The dose can be increased or decreased by turning the dose knob in either direction.
 - The dose knob turns 0.2 mg at a time.
 - Your pen contains 24 mg of medicine but you can only set a dose of up to 12 mg for a single injection.
 - The dose window shows the dose in mg. See **Examples A and B**.
- **Always check the dose window to make sure you have set the correct dose.**
Important: Do not press the injection button while setting your dose.

What should I do if I cannot set the dose I need?

- If your dose is more than 12 mg you will need more than 1 injection.
- You can give from 0.2 mg to 12 mg in a single injection.
 - If you need help dividing up your dose the right way, ask your doctor, nurse or pharmacist.
 - Use a new needle for each injection (**See Step 4 Attach needle**).
 - If you normally need to give 2 injections for your full dose, be sure to give your second dose.

What should I do if I do not have enough medicine left in my pen?

- If your pen contains less than 12 mg of medicine, the dose knob will stop with the remaining amount of medicine shown in the dose window.
- If there is not enough medicine left in your pen for your full dose, you may either:
 - inject the amount left in your pen, then prepare a new pen to complete your dose in full.
Remember to subtract the dose you have already received. For example, if the dose is 3.8 mg and you can only set the dose knob to 1.8 mg, you should inject another 2.0 mg with a new pen.
 - or get a new pen and inject the full dose.

Injecting your dose

Step 8 Insert the needle

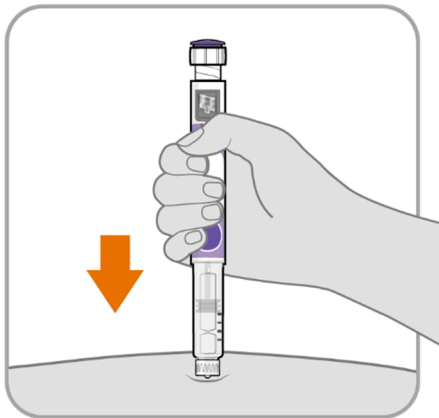

- Hold your pen so you can see the numbers in the dose window.
- Insert the needle straight into your skin.

Step 9 Inject your medicine

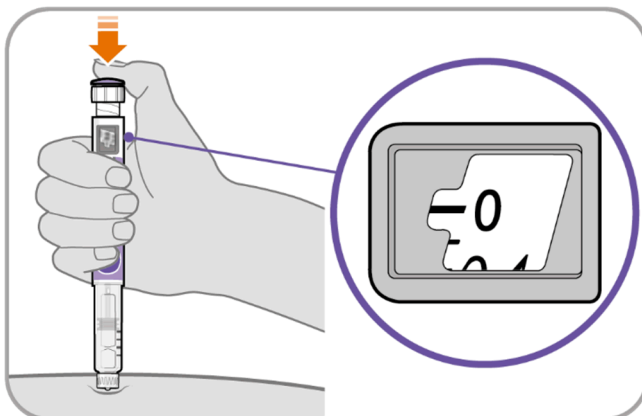

- Keep holding the needle in the same position in your skin.
- **Press the injection button** until it cannot go any further and “0” is shown in the dose window.

Step 10 Count to 10

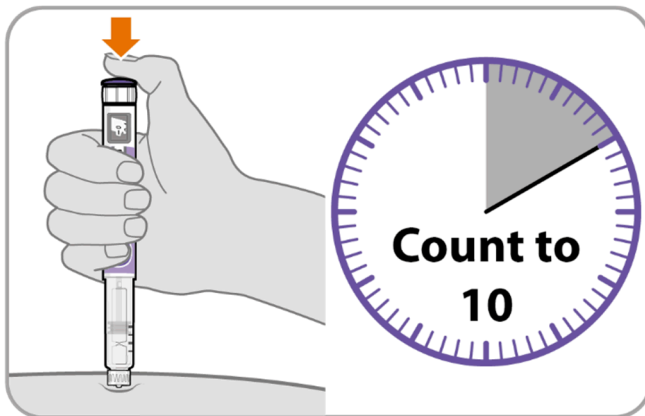

- **Continue to press the injection button while counting to 10.** Counting to 10 will allow the full dose of medicine to be given.
- After counting to 10, let go of the injection button and slowly remove the pen from the injection site by pulling the needle **straight out**.
Note: You may see a drop of medicine at the needle tip. This is normal and does not affect the dose you just received.

Step 11 Attach outer needle cover

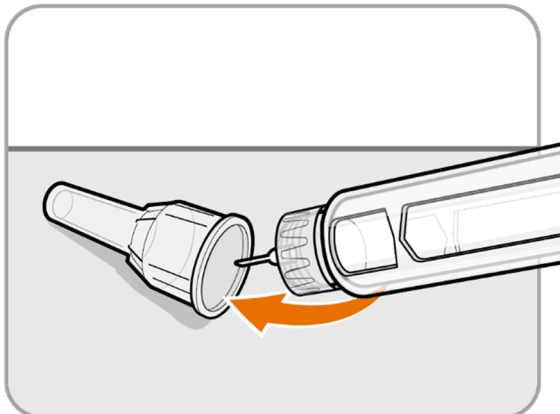

- Carefully place the outer needle cover back on the needle.
- Press on the outer needle cover until it is secure.
Caution: Never try to put the inner needle cap back on the needle. You may prick yourself with the needle.

Step 12 Remove the needle

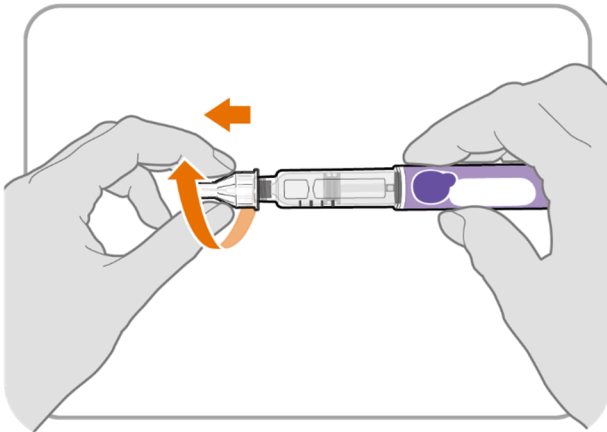

- Unscrew the capped needle from the pen.
- Gently pull until the capped needle comes off.
Note: If the needle is still on, replace the outer needle cover and try again. Be sure to apply pressure when unscrewing the needle.
- Dispose of your used pen needles in a sharps container as instructed by your doctor, nurse or pharmacist and in accordance with local health and safety laws. Keep the sharps container out of the reach of children. **Do not** reuse needles.

Step 13 Replace the pen cap

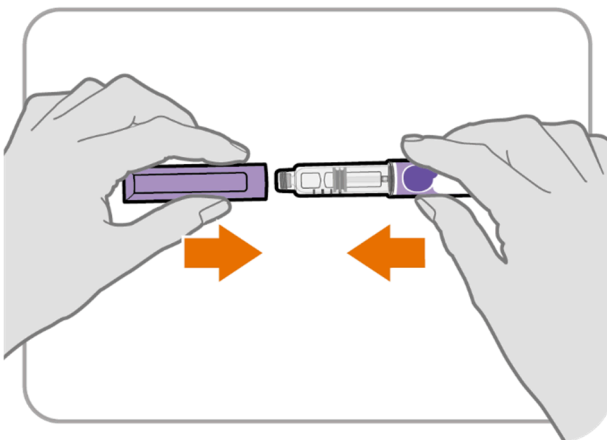

- Replace the pen cap back onto your pen.
- **Do not** recap the pen with a needle attached.
- If there is any medicine left in your pen, store in the refrigerator between uses (See sections 6.3 and 6.4).

Step 14 After your injection

- Press lightly on the injection site with a clean cotton ball or gauze pad, and hold for a few seconds.
- **Do not** rub the injection site. You may have slight bleeding. This is normal.
- You may cover the injection site with a small adhesive bandage, if needed.
- If your pen is empty or it has been **more than 28 days** after first use, throw it away even if it contains unused medicine. Throw away your pen in the sharps container.
- To help you remember when to dispose of your pen you can write the date of first use on the pen label and below:

Date of first use _____ / _____ / _____

Instructions for use *NGENLA 60 mg Pen*

Injection for subcutaneous (under the skin) use only
Keep this leaflet. These instructions show step-by-step directions on how to prepare and give a NGENLA injection.

Important information about your NGENLA pen

- NGENLA for injection is a multi-dose pre-filled pen containing 60 mg of medicine.
- NGENLA for injection can be given by a patient, caregiver, doctor, nurse or pharmacist. **Do not** try to inject NGENLA yourself until you are shown the right way to give the injections and read and understand the Instructions for use. If your doctor, nurse or pharmacist decides that you or a caregiver may be able to give your injections of NGENLA at home, you should receive training on the right way to prepare and inject NGENLA. It is important that you read, understand, and follow these instructions so that you inject NGENLA the right way. It is important to talk to your doctor, nurse or pharmacist to be sure you understand your NGENLA dosing instructions.
- To help you remember when to inject NGENLA, you can mark your calendar ahead of time. Call your doctor, nurse or pharmacist if you or your caregiver have any questions about the right way to inject NGENLA.
- Each turn (click) of the dose knob increases the dose by 0.5 mg of medicine. You can give from 0.5 mg to 30 mg in a single injection. If your dose is more than 30 mg, you will need to give more than 1 injection.
- A small amount of the medicine may remain in the pen after all doses have been correctly given. This is normal. Patients should not try to use the remaining solution but get rid of the pen in the correct way.
- **Do not** share your pen with other people, even if the needle has been changed. You may give other people a serious infection, or get a serious infection from them.
- Always use a new sterile needle for each injection. This will reduce the risk of contamination, infection, leakage of medicine, and blocked needles leading to the wrong dose.
- **Do not** shake your pen. Shaking can damage the medicine.
- The pen is **not recommended** for use by the blind or visually impaired without the assistance of a person trained in the proper use of the product.

Supplies you will need each time you inject

Included in the carton:

- 1 NGENLA 60 mg pen.

Not included in the carton:

- 1 new sterile needle for each injection.
- Alcohol swabs.
- Cotton balls or gauze pads.
- Adhesive bandage.
- A suitable sharps disposal container for disposal of pen needles and pens.

NGENLA 60 mg pen:

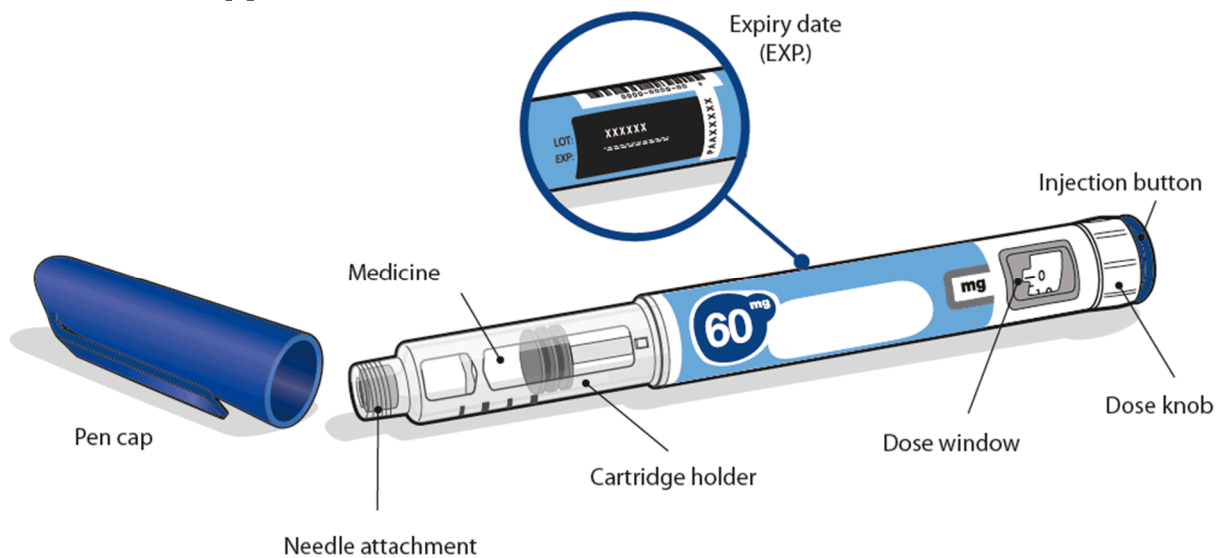

Needles to use

Pen needles are **not included** with your NGENLA pen. You can use pen needles up to a length of 8 mm.

- Needles to use with your NGENLA pen:
 - 31G or 32G
- Talk with your doctor, nurse or pharmacist about the right needle for you.

Sterile needle (example) not supplied:

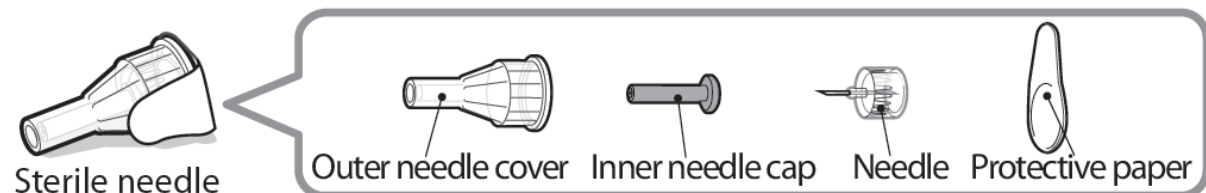

Caution: Never use a bent or damaged needle. Always handle pen needles with care to make sure you do not prick yourself (or anyone else) with the needle. **Do not** attach a new needle to your pen until you are ready for your injection.

Preparing for your injection

Step 1 Getting ready

- Wash and dry your hands.
- You can use your pen straight from the refrigerator. For a more comfortable injection, leave your pen at room temperature for up to 30 minutes. (See sections 6.3, 6.4 and 6.6).
- Check the name, strength, and label of your pen to make sure it is the medicine your doctor has prescribed for you.
- Check the expiry date on the pen label. **Do not** use if the expiry date has passed.
- **Do not** use your pen if:
 - it has been frozen, exposed to heat (above 32°C) or it has been more than 28 days after first use of the pen. (See sections 6.3 and 6.4).
 - it has been dropped
 - it looks broken or damaged
- **Do not** remove the pen cap from your pen - until you are ready to inject.

Step 2 Choose and clean your injection site

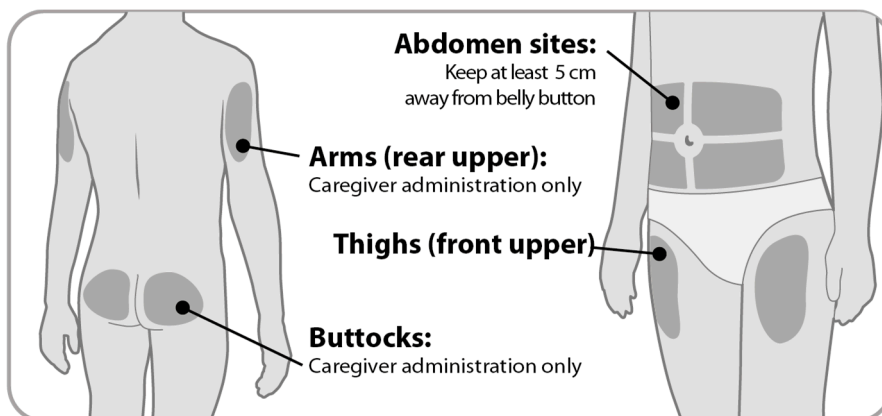

- NGENLA can be given in the abdomen (belly), thighs, buttocks, or upper arms.
- Choose the best place to inject, as recommended by your doctor, nurse or pharmacist.
- If more than 1 injection is needed to complete your full dose, each injection should be given in a different injection site.
- **Do not** inject into bony areas, areas that are bruised, red, sore or hard, and areas that have scars or skin conditions.
- Clean the injection site with an alcohol swab.
- Allow the injection site to dry.
- **Do not** touch injection site after cleaning.

Step 3 Check medicine

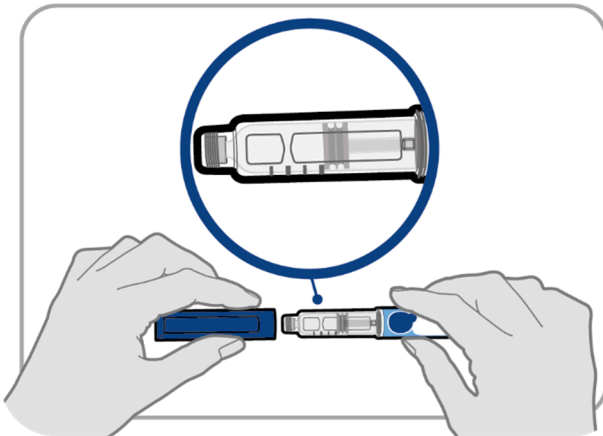

- Pull off the pen cap and keep it for after your injection.
- Check the medicine inside the cartridge holder.
- Make sure the medicine is clear and colorless to slightly light yellow. **Do not** inject the medicine if it is cloudy or dark yellow.
- Make sure the medicine is free of flakes or particles. **Do not** inject the medicine if it has flakes or particles.

Note: It is normal to see one or more bubbles in the medicine.

Step 4 Attach needle

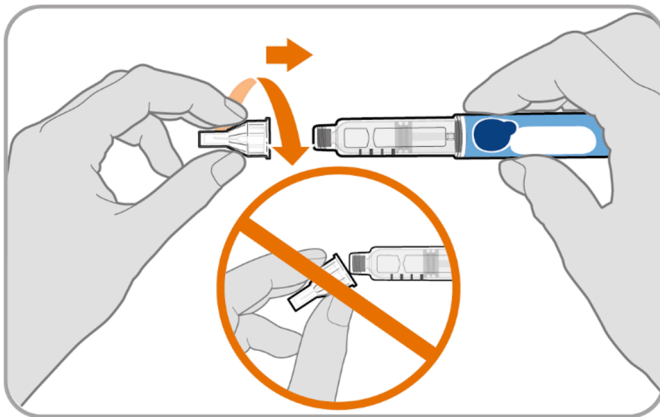

- Take a new needle and pull off the protective paper.
- Line the needle up with your pen keeping them both straight.
- Gently push and then screw the needle onto your pen.
Do not over tighten.

Note: Be careful not to attach the needle at an angle. This may cause the pen to leak.

Caution: Needles have sharp tips at both ends. Handle with care to make sure you do not prick yourself (or anyone else) with the needle.

Step 5 Pull off outer needle cover

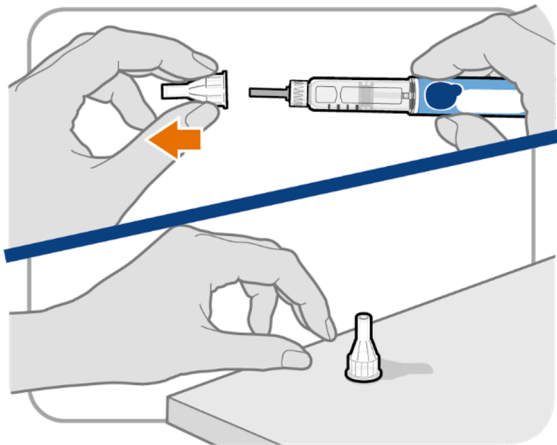

- Pull off the outer needle cover.
 - Make sure you keep the outer needle cover. You will need it later to remove the needle.
- Note:** You should see an inner needle cap after you have removed the outer cover. If you do not see this, try to attach the needle again.

Step 6 Pull off inner needle cap

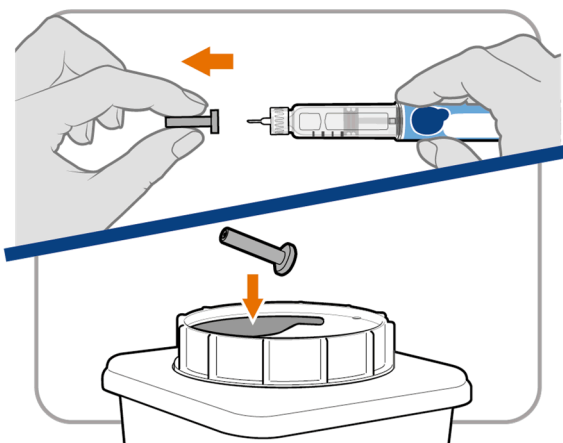

- Pull off the inner needle cap carefully to show the needle.
- Throw away the inner needle cap in a sharps container. It is not needed again.

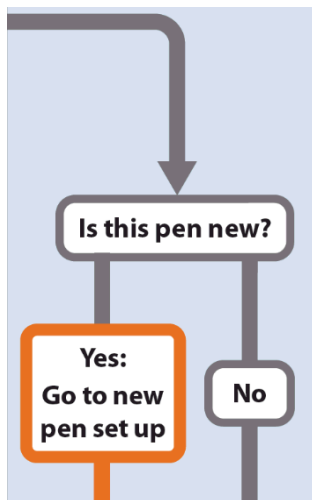

(‘Yes: Go to new pen set up’ has an arrow directing to ‘New pen set up (priming)’ and ‘No’ has an arrow directing to ‘Setting your prescribed dose’)

New pen set up (priming) – for the first use of a new pen only

You must set up each new pen (priming) before using it for the first time

- New pen set up is done before each new pen is used for the first time.
- The purpose of setting up a new pen is to remove air bubbles and make sure you get the correct dose.

Important: Skip Step-A through to Step-C if you have already set up your pen.

Step-A: Set knob to 1.0

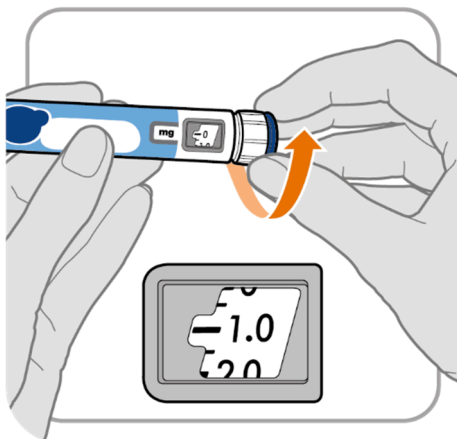

- Turn the dose knob to **1.0**.
Note: If you turn the dose knob too far, you can turn it back.

Step-B: Tap cartridge holder



- Hold the pen with the needle pointing up so that the air bubbles can rise.
- **Tap** the cartridge holder gently to float any air bubbles to the top.
Important: Follow Step-B even if you do not see air bubbles.

Step-C: Press button and check for liquid

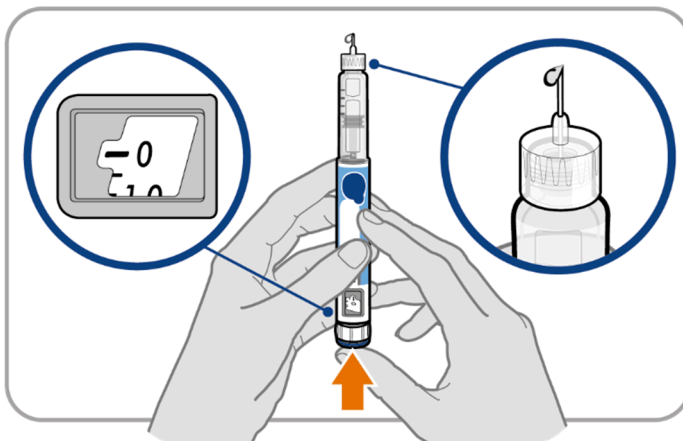

- **Press the injection button** until it cannot go any further and “0” is shown in the dose window.
- **Check** for liquid at the needle tip. If liquid appears, your pen is set up.
- Always make sure that a drop of liquid appears before you inject. If liquid has not appeared, repeat Step-A through to Step-C.
 - If liquid does not appear after you have repeated Step-A through Step-C five (5) times, attach a new needle and try one (1) more time.
Do not use the pen if a drop of liquid still does not appear. Contact your doctor, nurse or pharmacist, and use a new pen.

Setting your prescribed dose

Step 7 Set your dose

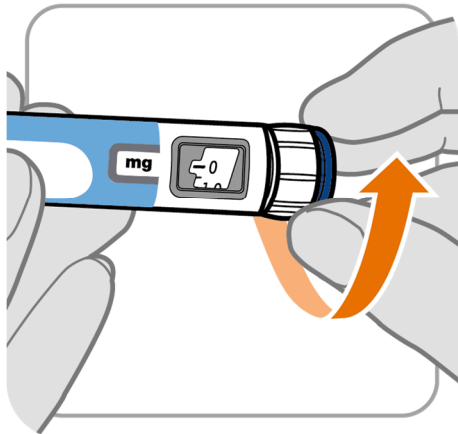

Example A:

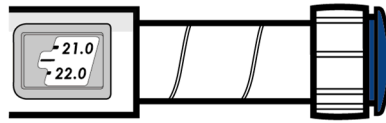

21.5 mg shown in the dose window

Example B:



30.0 mg shown in the dose window

- Turn the dose knob to set your dose.
 - The dose can be increased or decreased by turning the dose knob in either direction.
 - The dose knob turns 0.5 mg at a time.
 - Your pen contains 60 mg of medicine but you can only set a dose of up to 30 mg for a single injection.
 - The dose window shows the dose in mg. See **Examples A and B**.
- **Always check the dose window to make sure you have set the correct dose.**
Important: Do not press the injection button while setting your dose.

What should I do if I cannot set the dose I need?

- If your dose is more than 30 mg you will need more than 1 injection.
- You can give from 0.5 mg to 30 mg in a single injection.
 - If you need help dividing up your dose the right way, ask your doctor, nurse or pharmacist.
 - Use a new needle for each injection (**See Step 4 Attach needle**).
 - If you normally need to give 2 injections for your full dose, be sure to give your second dose.

What should I do if I do not have enough medicine left in my pen?

- If your pen contains less than 30 mg of medicine, the dose knob will stop with the remaining amount of medicine shown in the dose window.
- If there is not enough medicine left in your pen for your full dose, you may either:
 - inject the amount left in your pen, then prepare a new pen to complete your dose in full.
Remember to subtract the dose you have already received. For example, if the dose is 21.5 mg and you can only set the dose knob to 17 mg, you should inject another 4.5 mg with a new pen.
 - or get a new pen and inject the full dose.

Injecting your dose

Step 8 Insert the needle

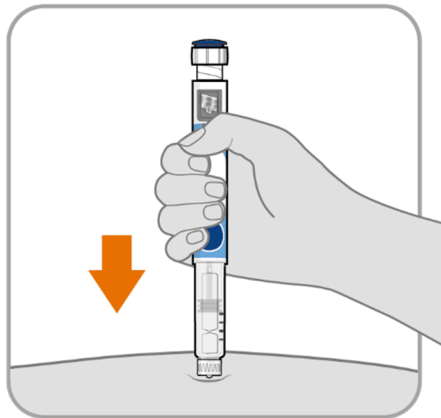

- Hold your pen so you can see the numbers in the dose window.
- Insert the needle straight into your skin.

Step 9 Inject your medicine

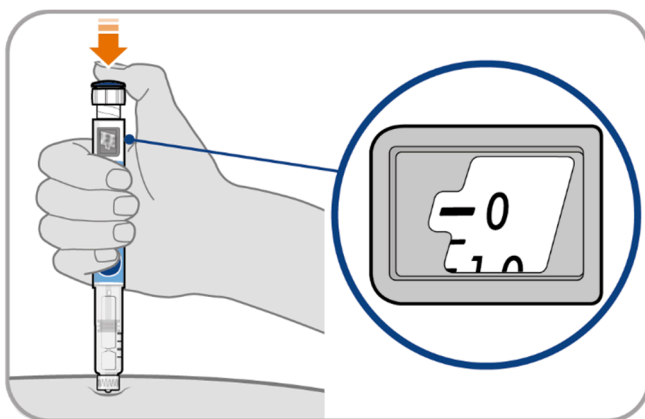

- Keep holding the needle in the same position in your skin.
- **Press the injection button** until it cannot go any further and “0” is shown in the dose window.

Step 10 Count to 10

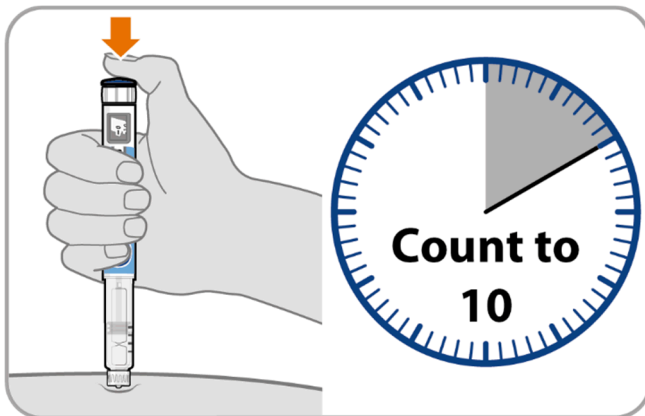

- **Continue to press the injection button while counting to 10.** Counting to 10 will allow the full dose of medicine to be given.
- After counting to 10, let go of the injection button and slowly remove the pen from the injection site by pulling the needle **straight out**.
Note: You may see a drop of medicine at the needle tip. This is normal and does not affect the dose you just received.

Step 11 Attach outer needle cover

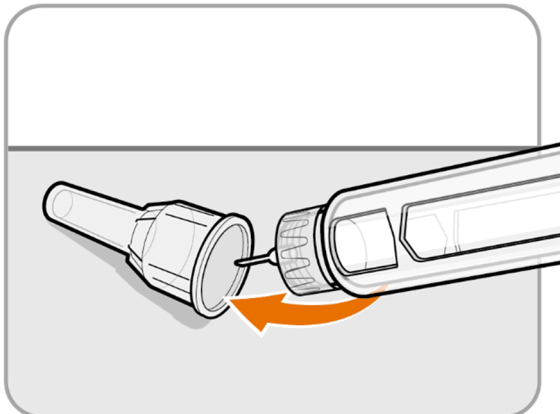

- Carefully place the outer needle cover back on the needle.
- Press on the outer needle cover until it is secure.
Caution: Never try to put the inner needle cap back on the needle. You may prick yourself with the needle.

Step 12 Remove the needle

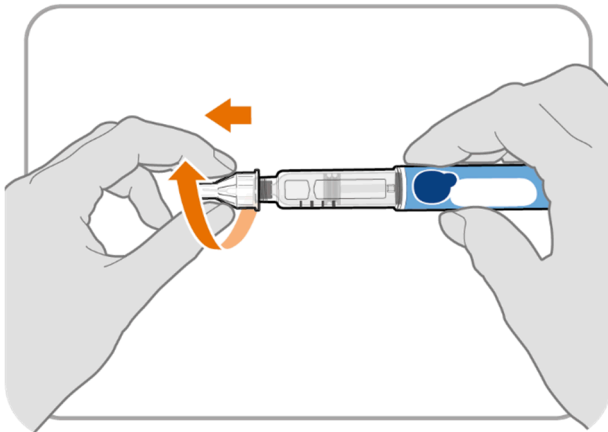

- Unscrew the capped needle from the pen.
- Gently pull until the capped needle comes off.
Note: If the needle is still on, replace the outer needle cover and try again. Be sure to apply pressure when unscrewing the needle.
- Dispose of your used pen needles in a sharps container as instructed by your doctor, nurse or pharmacist and in accordance with local health and safety laws. Keep the sharps container out of the reach of children. **Do not** reuse needles.

Step 13 Replace the pen cap

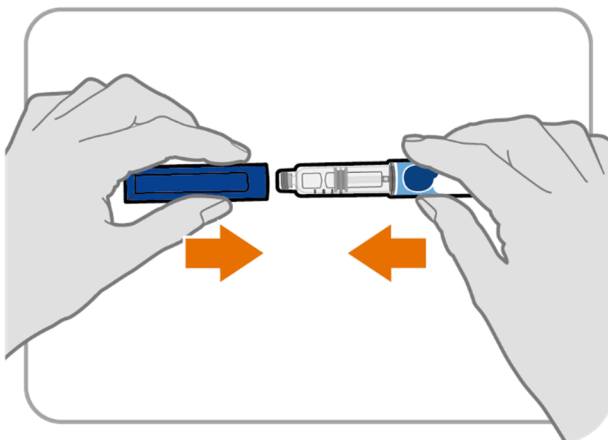

- Replace the pen cap back onto your pen.
- **Do not** recap the pen with a needle attached.
- If there is any medicine left in your pen, store in the refrigerator between uses (See sections 6.3 and 6.4).

Step 14 After your injection

- Press lightly on the injection site with a clean cotton ball or gauze pad, and hold for a few seconds.
- **Do not** rub the injection site. You may have slight bleeding. This is normal.
- You may cover the injection site with a small adhesive bandage, if needed.
- If your pen is empty or it has been **more than 28 days** after first use, throw it away even if it contains unused medicine. Throw away your pen in the sharps container.
- To help you remember when to dispose of your pen you can write the date of first use on the pen label and below:

Date of first use _____ / _____ / _____

NGE-SIN-0322/2

Date of last revision: November 2023